

INSTALLATION MANUAL



PC1150

This device complies with Parts 15 and 68 of the FCC rules. Operation is subject to the following two conditions: (1) this device may not cause harmful interference, and (2) this device must accept any interference received, including interference that may cause undesired operation.

FCC Reg. No.: F53CAN-73151-AL-E REN = 0.1B Plug Type : RJ31X

MADE IN CANADA

NOTES FOR UL INSTALLATIONS

This equipment is UL listed in accordance with UL 1023 (Household Burglar Alarm System Units). This equipment has not been investigated for compliance with UL 294, Access Control System Units.

This equipment has the capability of being programmed for operational features that are not allowed for UL recognized installations. To stay within the standard for household applications, the installer should stay within the following guidelines when configuring the system.

1. All components of the system should be UL listed for the intended application. Note elsewhere in this manual recommendations for a smoke detector and battery for use with this system.
2. This equipment is listed for "Local" applications only and should not be programmed for "Silent Alarm" (Section [11] zone definitions).
3. Maximum allowed Entry delay = 45 seconds
Maximum allowed Exit delay = 60 seconds
Minimum allowed Siren cutoff time = 4 minutes
4. The User Bypass must be enabled such that a User Code is required to Bypass zones (Section [14] light 1).
5. The installer should caution the user to not give system information (for example, Access Codes, Bypass methods, etc.) to casual users such as babysitters or home service people. Only the "One-Time" use code should be given to the casual user.
6. The installer should advise the user and note in the user manual:
 - a) The service organization name and telephone number
 - b) The programmed Exit time
 - c) The programmed Entry time
7. The Master Code should be changed from the factory default setting and the new Master Code recorded in the User manual.
8. This equipment is listed for Local applications only and thus the connection to a Central Receiving Station via the Digital Communicator has not been evaluated by UL and the following should be noted:
"The Burglar Alarm signal shall not be connected to a police emergency number."
"The receiving unit to which this equipment transmits signals has not been evaluated by UL."
9. Remote programming shall be disabled.

TABLE OF CONTENTS

INTRODUCTION

Features	3
Specifications	3

INSTALLATION

Mounting the Panel	4
Assembling The Unit	4
Mounting the Enclosure	4
Burglary Zone Wiring	5
Auxiliary Power Connection	5
PGM Terminal Connections	5
AC Power Wiring	5
Battery Connection	5
Telephone Line Wiring	5

KEYPAD FUNCTIONS

Introduction	6
Master Code	6
2nd Master Code	6
Installer's Programming Code	6
Arming	6
Auto-Bypass/Home-Away Arming	6
Arming Without Entry Delay	7
Disarming	7
[*]+[1]: Zone Bypassing	7
[*]+[2]: Display Trouble Conditions	7
[*]+[3]: Display Alarm Memory	8
[*]+[4]: Downloading Call-up Command	8
[*]+[5]: User Programming Command	9
[*]+[6]: User Function Command	9
Setting the Clock	[*]+[6]+[Master Code]+[1] 10
Set Auto-Arm Time	[*]+[6]+[Master Code]+[2] 10
Auto-Arm Enable/Disable	[*]+[6]+[Master Code]+[5] 10
Door Chime Enable/Disable	[*]+[6]+[Master Code]+[6] 10
Siren Test	[*]+[6]+[Master Code]+[8] 10
Installer's Test	[*]+[6]+[Master Code]+[0] 10
Utility Output Command	[*]+[7] or [*]+[7]+[Access Code] 11
Installer's Programming Command	[*]+[8]+[Installer's Code] 11
Arming Without Entry Delay	[*]+[9]+[Access Code] 11
Arming For The Night	[*]+[1] 11
Quick-Exit	[*]+[0] when Armed 11
Keypad Zones	11

PROGRAMMING GUIDE

Program Data Review	12
Sections [12], [13], [14], [16], [31], [32]	12
Binary Data Display	13
HEX Data Programming	13

PROGRAMMING SECTIONS

[01] 1st Phone Number 14
[02] 1st Account Code 14
[03] 2nd Phone Number 14
[04] 2nd Account Code 14
Reporting Code Sections [05] to [10] 14
[05] Zone Alarm Reporting Codes 14
[06] Zone Restoral Reporting Codes 15
[07] Closing (Arming) Reporting Codes / Partial Closing Reporting Code 15
[08] Opening (Disarming) Reporting Codes / After Alarm Reporting Code 16
[09] Priority Alarms and Restorals 16
[10] Maintenance Alarms and Restorals 16
[11] Zone Definitions 16
[12] 1st System Option Code 18
[13] 2nd System Option Code 18
[14] 3rd System Option Code 19
[15] Communication Variables 19
[16] Zone Bypass Mask 19
[17] System Times 19
[18] Auxiliary Delay Zone Entry/Exit Times 20
[19] System Clock Times 20
[20] Installer's Code 20
[21] Master Code 20
[22] 2nd Master Code 20
[23] Communication Formats 21
[24] Programmable Output Options / PGM Terminal 22
[25] Communicator Call Directions 23
[26] Downloading Telephone Number 23
[27] Downloading Access Code 23
[28] Panel Identification Code 23
[29] Number of Rings Before Answering 23
[30] Reset to Factory Default 24
[31] 4th System Option Code 24
[32] 5th System Option Code 25
[33] Answering Machine Double Call Timer 25
[90] Installer's Lockout Enable 25
[91] Installer's Lockout Disable 25

FOR THE RECORD 26

PROGRAMMING WORKSHEETS 27-34

HOOKUP DIAGRAM 35

LIMITED WARRANTY 36

NOTES FOR UL INSTALLATIONS *Inside front cover*

FCC COMPLIANCE STATEMENT *Inside rear cover*

INTRODUCTION

FEATURES

Keypad Programmable

The PC1150 comes complete with a default program so that it is operational straight from the box with a minimum of programming. The control panel is completely programmable from the keypad.

EEPROM Memory

The panel uses EEPROM memory which will retain all program information even if AC and battery power is removed from the panel. The EEPROM memory can be reprogrammed thousands of times.

Static/Lightning Protection

The PC1150 has been carefully designed and tested to provide reliable protection against static and lightning induced transients. The special "Zap-Trac" circuit board design catches high voltage transients right at the wiring terminals, and transient protection devices are placed in all critical areas to further reduce damaging voltages.

Supervision

- Low or disconnected battery
- Loss of AC power
- Fuse open
- Loss of time on system clock
- Microprocessor "Watchdog" circuit

Operation

- Download / Upload capability
- Programmable auto downloading
- Swinger shutdown
- Transmission delay
- Six Access Codes
- "Master key" code
- All zones programmable as fire zones
- Programmable test transmission
- Zone bypass from the keypad
- Four zones
- Siren zone
- Programmable output
- Four programmable outputs

SPECIFICATIONS

PC1150 Control Panel

- Four fully programmable zones
- End-of-Line (EOL) resistor supervised option
- Maximum zone zone resistance: 100 ohms
- Siren output: 1 amp
- Siren sounds steady for burglary; pulsed for fire
- Programmable Output: 50 mA with 9 options
- Auxiliary power output: 50 mA
- Battery: 12VDC, 1.2Ah minimum, gelled electrolyte
- Transformer: 16 VAC, 40 VA
- Panel dimensions: 10" high x 8" wide x 3" deep (254 x 208 x 76 mm)
- Surface mount
- Panel colour: light beige

PC1150 Keypad

- Three keypad activated zones
- 4 system lights: Ready, Armed, System
- 4 zone lights

INSTALLATION

Mounting the Panel

The keypad should be located close to the designated "Entry-Exit" door and be mounted at a height convenient for all users. Select a dry location close to an unswitched AC source and close to the telephone line connection. Remove the printed circuit board, the mounting hardware and the keypad from the cardboard packaging.

Assembling The Unit

From the speaker-side of the mounting bracket, press the four white nylon circuit board mounting studs into the holes provided so that the studs face away from the speaker. If it is not attached, attach the communicator to the control panel; ensure that all pins on the communicator are inserted into the control panel's sockets. Align the assembled unit with the mounting bracket so that the communicator's ribbon wire aligns with the cut-out on the mounting bracket. The wiring terminals should be behind the speaker, with the communicator's terminals facing up. Press the assembled unit onto the mounting studs.

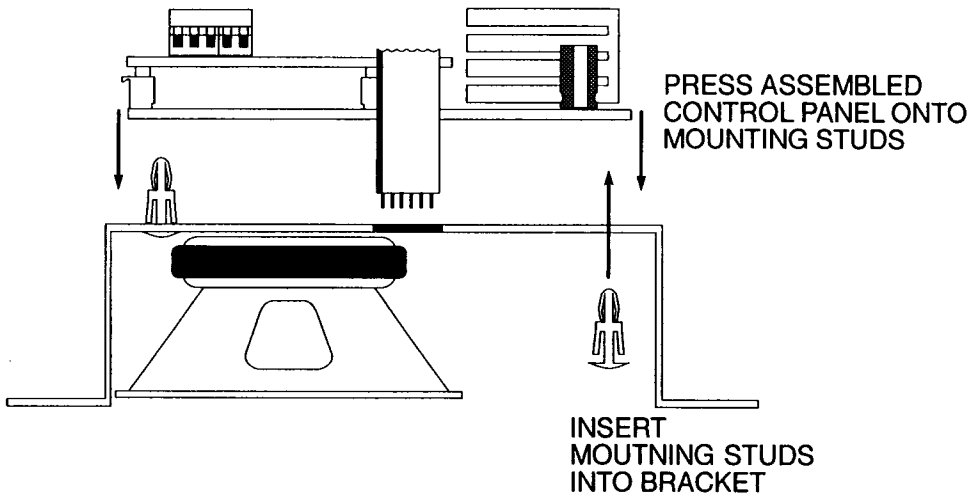

Mounting the Enclosure

With the battery box opening facing down, mount the enclosure in a prepared opening in the wall; at least one side of the metal box should be secured to a wall stud. Place the battery box into the enclosure and secure the battery box with a screw. Pull all cables into the cabinet and prepare them for connection. Use a meter to test the wiring for opens, shorts and grounds. Place the battery into the battery box, but do not connect it to the panel yet. Connect the speaker wires to the BELL terminals (red to + and black to -); you may wish to trim the length of the speaker wires to reduce clutter behind the panel. If the wires are trimmed, ensure that their ends are properly prepared for connection to the terminals.

Align the grey strip on the communicator's ribbon wire with the RED terminal on the keypad circuit board plug and press the ribbon wire into place. Complete all wiring to the control panel before applying AC power or connecting the battery. With all wiring completed, connect the battery to the unit. Insert the unit into the enclosure so that the speaker faces out of the unit and is on the left side of the enclosure. Mount the front panel on the enclosure, and secure with four screws.

NOTE: Complete all wiring to the control panel before applying AC power or connecting the battery.

Burglary Zone Wiring

Burglary zone definition, (for example, Delay, Instant, 24-Hour, and so on) is programmed using the keypad. Refer to Programming Guide Section [11].

NOTE: For UL installations, zone inputs must be terminated with 1kΩ end-of-line resistors.

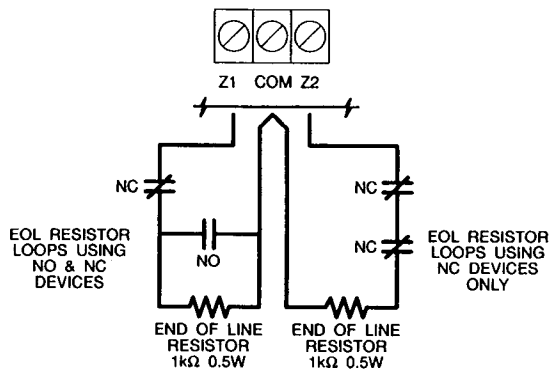

Burglary Zone Wiring Chart

Wire Gauge	Maximum wire length to End of Line Resistor (feet/meters)
24	1900 / 579
22	3000 / 914
20	4900 / 1493
19	6200 / 1889
18	7800 / 2377

Figures are based on maximum loop resistance of 1000 ohms.

Auxiliary Power Connection

The auxiliary power supply can be used to power motion detectors and other devices that require 12 VDC. The total load for the Auxiliary power output must be calculated for all devices connected across the AUX +/– terminals and for devices connected between the AUX + and PGM terminals. The output current cannot exceed 50 mA.

PGM Terminal Connections

The PGM terminal is a switched negative output which can be controlled by various programming options; refer to Programming Guide Section [24]. Devices controlled by the PGM output must be connected between the switched negative PGM terminal and the AUX+ terminal.

AC Power Wiring

Complete all wiring to the control panel before applying AC power or connecting the battery. The transformer should not be connected to an outlet that is controlled by a switch.

Battery Connection

If the battery is connected in reverse, the 5 A fuse will open and will need to be replaced. The battery charging voltage is factory set and normally needs no adjustment. If the battery charging voltage is out of adjustment, contact your service representative.

If AC power is OFF and the battery voltage drops to approximately 9.5 V or lower, the battery will be disconnected and the panel will power down. To power up again, AC power will have to be re-established. This feature is designed to prevent damage to the battery due to deep discharging.

Telephone Line Wiring

Do not connect the alarm panel communicator to telephone lines intended for use with facsimile (fax) machines. These lines may incorporate a voice filter which disconnects the line if other than fax signals are detected. This may result in incomplete transmissions from the alarm panel communicator.

KEYPAD FUNCTIONS

Introduction

The PC1150 keypad provides complete control of the PC1150 control panel. The panel can be completely programmed from the keypad. The 4 zone lights provide alarm and status indication for the alarm circuits, and three function lights advise the user of system status. The built-in sounder lets the user hear correct key entries and other alert signals. The 12-digit keypad is used for code entry and other programming functions. Alarms may be activated by pressing and holding two keys at the same time; [1]+[3], [4]+[6] and [*]+[#]. All other keypad entries are made by pressing one key at a time.

Master Code

The Master Code is factory set at "1234"; this code should be changed after the system is installed. The Master Code is used to arm and disarm the panel, to reset the sounder after an alarm, to program up to 5 additional Access Codes, and to perform other user functions. The panel's default program allows the user to change the Master Code. The panel can be programmed by the installer so that the user cannot change the Master Code. See Section [13] Second System Option Codes, Light 2.

2nd Master Code

A Second Master Code can be programmed into the PC1150. This code can be changed by the installer only, and is useful where there are multiple panels in an installation. The Second Master Code may be used as a "Master Key". The 2nd Master Code does not have a factory-set code.

Installer's Programming Code

The Installer's Programming Code is factory set as "1212"; this code should be changed when the system is installed. Using this code and the [*][8] command, the installer can perform programming functions.

Arming

Before arming the panel, close all protected doors and windows and stop movement in areas protected by motion detectors. If the "System" light is on, check for trouble conditions (refer to [*][2] Display Troubles) and correct the condition. Ensure that any bypassed zones are bypassed intentionally; refer to [*][1] Bypass Zones. If the "Ready" light is not on, one or more zones are open; the system can only be armed when the "Ready" light is ON.

To arm the system, enter a 4-digit Access Code. As each digit is entered, the keypad sounder will beep. When a valid Access Code has been entered the "Armed" light will come ON and the keypad will beep 6 times. If the Access Code has been entered incorrectly, the keypad will sound a single long tone. Press the [#] Key and enter the Access Code again.

When a valid Access Code has been entered and the "Armed" light is ON, leave the premises through the designated Entry-Exit door before the Exit Delay expires. At the end of the Exit Delay, all lights on the keypad will be shut OFF except for the "Armed" light.

Refer to [*][8] Installer's Programming Section for instructions on changing the Exit Delay time.

Auto-Bypass / Home-Away Arming

If an Access Code is entered and the Exit-Entry zone is not activated, the system will arm with interior zones automatically bypassed if those zones have been programmed as "Home-Away" zones.

This feature is designed for the user who wishes to remain at home with the system armed. When this feature is enabled, the user does not have to manually bypass the interior zones.

To reactivate the automatically bypassed interior zones, enter [*][1]. This command provides a quick means of fully arming the system before retiring for the night. This feature is useful for the user who has a keypad located outside the areas protected by the interior zones.

Arming Without Entry Delay

To eliminate the Entry Delay, arm the system by entering [*][9][any Access Code]. An exit through a Delay Zone may be made as in normal arming. The system will arm as described in Auto-Bypass / Home-Away arming whether an exit is made or not. The "Armed" light will FLASH to indicate that the system is armed and that there is no entry delay. If any zone is activated, an alarm will sound immediately.

Disarming

Enter the premises through the designated Entry-Exit door. The keypad will sound a tone to indicate that the system must be disarmed. Go to the keypad and enter an Access Code. If an error is made entering the code, press the [#] Key and enter the code again. The "Armed" light will be shut OFF and the sounder will be silenced. A valid Access Code must be entered before the Entry Delay expires or an alarm will sound. To change the Entry Delay, refer to Installer's Programming Section [17].

If an alarm occurred while the panel was armed, the "System" light and the zone lights of the zones that went into alarm will FLASH for two minutes. Press the [#] Key to cancel the flashing display and to return the panel to the "ready" mode. Refer to [*][3] Alarm Memory Display.

[*][1]: Zone Bypassing

A bypassed zone will not cause an alarm. Use zone bypassing when access is needed to part of the protected area or if damage to sensors or wiring cannot be repaired immediately. The panel can be armed with one or more zones bypassed even if the zones are open. The "Ready" and "System" lights will be ON if a zone is bypassed. Note that fire zones **cannot** be bypassed.

Enter [*][1] to display the bypassed zones; the Zone Lights of bypassed zones will come ON. Ensure that any zone displayed as being bypassed is intentionally bypassed. Zone bypasses are automatically cancelled when the panel is disarmed.

To Bypass Zones:

Enter [*][1]; the "System" light will start flashing.

Enter the number of the zone to be bypassed; the corresponding zone light will come ON to indicate that the zone is bypassed. To remove a bypass, enter the zone number and its zone light will be shut OFF. Enter the zone numbers for all zones that are to be bypassed. Press [#] to return to "ready".

To Recall Bypassed Zones:

Enter [*][1][9][#].

This command will recall the last zone or group of zones that was bypassed. If the same group of zones are bypassed regularly, the Recall feature can be used instead of bypassing the zones individually.

Bypass Disable:

The PC1150 can be programmed by the installer to prevent certain zones from being bypassed. Lights for these zones will not come ON in response to the bypass command. Refer to Section [16] Zone Bypass Mask.

[*][2]: Display Trouble Conditions

The PC1150 continuously monitors a number of trouble conditions. If one of these conditions occurs, the keypad "System" light will come ON and the sounder will sound two short beeps every 10 seconds. To silence the sounder, press the [#] Key; the sounder will be silenced but the "System" light will remain ON until the trouble condition is cleared. Refer to Section [10] Maintenance Alarms & Restorals for a list of trouble conditions that can be reported to the monitoring station.

To display trouble conditions, enter [*][2]. Trouble conditions are represented with the following lights:

Light

- Zone 1 Low Battery.** If the battery is disconnected, its voltage is low or the battery fuse is open, a trouble will be displayed and can be reported.
- Zone 2 AC Failure.** On loss of AC power, the "System" light will come ON but the keypad buzzer will not sound. The keypad buzzer will sound if AC power remains off and the battery reaches a low voltage. The delay before transmitting an AC Failure can be programmed from 1 to 99 minutes; see Programming Section [17].
- Zone 3 Fuse Failure - Siren or AUX Output.** A trouble is displayed if the siren fuse is open. If the AUX output fuse fails, it will not be displayed but will be reported if programmed to do so.
- Zone 4 Unsuccessful Communication Attempt.** If the digital communicator is cannot communicate with the monitoring station after 8 attempts at each phone number, a trouble is generated. See Section [25], Communication Variables. If a later attempt at communication is successful, the trouble is cleared. The trouble can also be cleared by pressing the [#] Key to return to "ready" from the Display Trouble Conditions mode.
- "Armed" Loss of Time on System Clock.** When the PC1150 is powered up or reset, its internal clock will need to be reset to the correct time. This trouble is cleared after exiting the Display Trouble Conditions mode or when the time is reset; refer to [*][6] User Function Commands for instructions for setting the time. **NOTE:** A loss-of-time trouble will *not* be generated if the Test Transmission and Auto-Arm times are not programmed.

NOTE: If [9] is pressed while in the Display Trouble Conditions mode, the last set of trouble conditions will be displayed on the zone lights. This "trouble memory" is useful as a diagnostic tool when installing and servicing the PC1150.

[*][3]: Display Alarm Memory

Alarms caused during the previous armed period are stored in memory. To display the zones that went into alarm, enter [*][3]. The "System" light will FLASH and the alarms will be displayed on the flashing zone lights.

In addition to the last alarm memory, there are two history levels. After entering the memory mode, pressing any key from [0] to [9] will display two levels of alarm history. Each time a key is pressed, the keypad will beep 1, 2 or 3 times to indicate which level of history is being viewed.

When the panel is armed and there are alarms in the first history level, the first level will be cleared and its alarms moved to the second level. The second level events will be moved to the third level, and the existing third level events will be deleted.

[*][4]: Downloading Call-up Command

The [*][4] command is used to initiate a call to the downloading computer so that the panel can be accessed by the computer. To be operational, this command must be enabled in the Section [14] Light 2. Sections [26], [27] and [28] must be programmed with the downloading computer's telephone number, the downloading access code and the panel identification code. The [*][4] command can be programmed to require that an Access Code be entered in order for the downloading call-up command to function; refer to Section [14] Light 4.

[*]+[5]: User Programming Command

The [*][5] programming command allows the user to program Access Codes. The first Access Code is the Master Code and the installer may program the panel so that the user not able to change the Master Code; refer to Section [13]. The 6th code may be changed from a regular code to a One-Time Use code; refer to Section [13] Light 5.

The One-Time Use code allows someone, such as maintenance personnel, to enter a code to disarm and then later re-arm the system. After the code is used to arm the system, it is deleted and may not be used again. **NOTE:** If the [*][0] Quick-Arm command is used to arm the system, the one-time use code will **not** be erased.

Programming Access Codes:

Enter [*][5][Master Code]. The "System" light will FLASH and the zone lights will indicate which Access Codes have been programmed and which Access Code is presently being programmed:

Zone Light	Access Code is...
OFF	not programmed
ON steady	programmed
Flashing	presently being programmed

When the programming mode is entered, Zone Light 1 will be ON to indicate that the Master Code is programmed with the factory default code. The Master Code may be changed here or in Section [21] if the installer chooses to disable the user's ability to change the Master Code. Note that Access Codes 5 and 6 are represented by the "Ready" and "Armed" lights.

Changing or Adding a Code

To change Access Codes 1 to 6, enter the number of the code to be changed; the corresponding zone light will begin to FLASH. Enter a new 4-digit Access Code; do not press [*] or [#] when entering the code. After the code is entered, the keypad will beep 3 times and the zone light will stop flashing and remain ON. If you are changing an existing code, the new code will replace the old one. If you wish to program another code, press the number key for the code to be programmed and enter the new 4-digit code. Press the [#] Key to return to "ready".

Erasing a Code

To erase a code, enter [*][5][Master Code]. Enter the number of the code to be erased; the zone light for the code will FLASH. Enter [****] to erase the Access Code. **NOTE:** The Master Code cannot be erased. If the Master Code is forgotten and the panel is left disarmed, program a new Master Code using the [*][8][Installer's Code][21] command, or use the Second Master Code to reprogram the Master Code.

EEPROM Reset

If all Access Codes are forgotten and the panel is armed, refer to Programming Section [30] for methods of resetting the panel to the factory default program.

[*]+[6]: User Function Command

The [*][6] User Function Command is used to set various system times and to enable or disable a number of system features. When the command is entered, the "System" light will begin to FLASH.

Enter [*][6][Master Code][Number from list below]:

- | | |
|------------------------------------|---|
| [1] Set System Clock (Enter HH:MM) | [6] Door Chime Enable/Disable |
| [2] Auto-Arming Time (Enter HH:MM) | [8] Siren Test Function |
| [5] Auto-Arm Enable/Disable | [0] Installer's Test (turn off after use)
(This function will turn off automatically on arming.) |

Items [5], [6] and [0] turn ON and OFF various features. When a key is pressed and the feature is being turned ON, the keypad sounder will beep 3 times. If the feature is being turned OFF, the keypad will sound one long beep.

Setting the Clock

[*]+[6]+[Master Code]+[1]

The System Clock uses a 24-hour clock format. For example, 8:05 AM would be entered as 0805; 1:30 PM would be entered as 1330.

If the system is without power (both AC and battery), it cannot continue to keep time. When the panel is powered up, the system clock must be reset. If the time needs to be reset, the "Armed" light will come ON when [*][2] is entered to display trouble conditions. Note that the loss-of-time trouble will not be generated if the Auto-Arm and Test Transmission times are not programmed with valid times (programming 9999 for the Auto-Arm and Test Transmission times will disable these features; see Section [19]).

Set Auto-Arm Time

[*]+[6]+[Master Code]+[2]

Refer to Auto-Arm Enable/Disable for instructions on enabling or disabling this feature. For Auto-Arming to work, it must be enabled and a valid time must be programmed.

The PC1150 can be programmed to arm at the same time each day. Before the system Auto-Arms, the siren will sound one short burst every 10 seconds for a one minute period if Section [32] Light 2 is OFF. If any key is pressed during the one minute warning period, Auto-Arming will be cancelled; the system will attempt to Auto-Arm at the same time the next day.

To set the Auto-Arm time, enter [*][6][Master Code][2]. Then enter the Auto-Arm time in the 24-hour format (for example, 2:30 pm would be entered as 1430).

Auto-Arm Enable / Disable

[*]+[6]+[Master Code]+[5]

NOTE: For UL installations, the Auto-Arm feature must always be disabled.

When this feature is enabled, the system will automatically arm at the same time each day. The time for Auto-Arming may be programmed in Section [19] or set using the [*][6][Master Code][2] Set Auto Arm Time command.

When the feature is being enabled, the keypad will sound 3 quick beeps when [5] is pressed. When the feature is being disabled, the keypad will sound a single long tone when [5] is pressed.

Door Chime Enable / Disable

[*]+[6]+[Master Code]+[6]

When this feature is enabled, the keypad will beep 5 times when any Delay or Instant zone is opened or closed; the door chime will not operate with other zone definitions. Any Delay or Instant zones that are bypassed will not chime. The door chime works only when the system is disarmed.

When the feature is being enabled, the keypad will sound 3 quick beeps when [6] is pressed. When the feature is being disabled, the keypad will sound a single long tone when [6] is pressed.

Siren Test

[*]+[6]+[Master Code]+[8]

Entering this command will sound the siren and turn ON all the keypad lights for 2 seconds.

Installer's Test

[*]+[6]+[Master Code]+[0]

This feature allows system to be walk tested. When this command is entered, the siren will sound for 2 seconds each time a zone is activated. When performing a walk test, each zone should be tripped individually. To cancel the test mode, arm and then disarm the system.

NOTE: The communicator will transmit all alarms and restorals during the test mode. If this is not desired, temporarily disable the communicator in Section [12], Light 1.

Utility Output Command

[*]+[7] or [*]+[7]+[Access Code]

The Programmable Output (PGM terminal) can be programmed to be activated by a keypad command. This output can be used to operate devices such as door strikes or special lighting. Depending on the option chosen, the [*][7] command may or may not require an Access Code to be entered. When the [*][7] command is entered, the sounder and the PGM output will be activated for 5 seconds.

Installer's Programming Command

[*]+[8]+[Installer's Code]

The PC1150 is programmed from the keypad by using commands in the [*][8] section. These commands are described in detail in the Programming Section of this manual. The default Installer's Code is [1212].

Arming Without Entry Delay

[*]+[9]+[Access Code]

Entering [*][9] before entering an Access Code will arm the panel and remove the Entry Delay from the delay zones. All "Home-Away" zones will also be automatically bypassed. When armed using the [*][9] command, the "Armed" light will FLASH to remind the user that the system is armed without the entry delay. This command allows the user to remain at home and have an instant alarm on the entry doors.

Arming For The Night: [*]+[1]

When retiring for the night, the user may reactivate bypassed interior "Home-Away" zones by entering the [*][1] command. When this command is entered, the "Armed" light will FLASH to remind the user that there is no entry delay. The [*][1] command will not remove bypasses from zones that have been manually bypassed.

Quick-Exit: [*]+[0] when Armed

NOTE: This feature must not be enabled on UL installations.

Entering [*][0] when the system is armed will allow the user to leave the premises through any delay zone without altering the status of the system. This feature must be enabled for it to be operational; Quick-Exit may be enabled at Section [32] Light 4.

After [*][0] is entered, only one armed delay zone may be opened within 2 minutes. Any additional openings, or openings after the 2-minute delay will cause an alarm.

Keypad Zones

There are three zones which can be activated by pressing and holding two keys on the keypad. For these alarms to be transmitted, the keypad zones must be enabled in Programming Section [09] Alarm and Restoral Codes.

[1]+[3] Press and hold [1]+[3] for 1 second to sound an alarm. A pulsed tone will sound, and the alarm will be reported to the monitoring station if transmission is enabled. The keypad will sound a series of short beeps once the panel has accepted the alarm.

[4]+[6] Press and hold [4]+[6] for 1 second to generate a silent alarm alarm. The siren will not sound when this function is activated. If programmed for transmission, the keypad will sound a series of short beeps upon successful completion of the transmission to the monitoring station.

[*]+[#] Press and hold [*]+[#] for 1 second to generate an alarm. This alarm may be programmed as either silent or audible. When programmed as audible, the siren will sound a steady tone; refer to Section [12], Light 6. Keypad audible annunciation for this alarm is programmable in Section [14], Light 5, as "audible" (3 beeps) or "silent" (no buzzer feedback). If programmed as "audible", the buzzer will sound once the key input is accepted.

[#] If the PC1150 is armed and Zone 1 is a Delay zone, Zone 1 can be opened without an alarm sounding if the [#] Key is pressed and held before the zone is opened. This feature allows a door to be opened without the system having to be disarmed. If Zone 1 is still open when the [#] Key is released, there will be an instant alarm.

PROGRAMMING GUIDE

With the panel disarmed, enter [*][8][Installer's Code]. The default Installer's Code is 1212. The Installer's Code should be changed after the system is installed; refer to Section [20] Installer's Code. Note that the panel can only be programmed while it is disarmed.

When the Installer's Programming Command is entered, the "System" light will FLASH to indicate that the panel is ready for programming. **NOTE:** If no key entry is made for 2 minutes, the panel will return to the "ready" mode and the Installer's Programming Command will have to be entered again.

With the "System" light flashing, enter 2 digits for the Section you wish to program; Programming Sections range from [01] to [33], and each section is programmed independently.

Once the 2 digits for the Section you wish to program are entered, the keypad will beep 3 times; the system is now ready to accept data for the selected Section. Most sections contain groups of 2-digit numbers; the keypad will beep twice after each 2-digit number is entered.

When a Section is entered, the Zone Lights will indicate the value of the first digit in the Section in binary format (see Binary Data Display). To change the first digit, enter a new digit from the keypad. If you wish to keep the first digit unchanged, enter the same number. When the first digit has been entered, the Zone Lights will display the value of the second digit.

When all data for the Section is completely entered, the keypad sounder will beep several times to indicate that the expected data has been entered. When a Section is completely programmed, enter the number of the next Section that is to be programmed.

It is not necessary to program all 2-digit numbers in any given Section. A Section can be entered and selectively programmed by going only to the digits you wish to change. After your changes have been made, press the [#] Key to return to the programming mode. You may then enter another Section for programming. For 2-digit numbers, both digits must be programmed before pressing the [#] Key. Only the data entered before pressing the [#] Key will be changed in the EEPROM.

Program Data Review:

- Enter the Installer's Programming Command: [*][8][Installer's Code]
- Enter the Section you wish to program by entering the 2-digit section number.
- The 4 Zone Lights will represent the value, in binary format, of the first digit in the section.
- At the end of the Section, the keypad will beep several times and then return to the program mode so that another Section can be selected for review or programming.

Sections [12], [13], [14], [16], [31], [32]

These sections allow you to enable or disable various system functions. Refer to the Programming Worksheets to see which features are represented by the Zone, "Ready" and "Armed" lights. If a feature is enabled, its Light will be ON; if a feature is disabled, its Light will be OFF.

To enable or disable a feature, press a number from 1 to 6. If a feature is being enabled, its light will come ON; if a feature is being disabled, its light will be shut OFF. All functions can be turned OFF at once by pressing [0]. When all selections have been made, press [#] to save the changes and return to the program mode.

Binary Data Display

Zone lights 1 through 4 are used to display the value of each digit of data in a binary format as shown here:

HEX data entry
Refer to HEX Data Programming

Value	0	1	2	3	4	5	6	7	8	9	A	B	C	D	E	F
Zone 1	<input type="checkbox"/>	<input checked="" type="checkbox"/>	<input type="checkbox"/>	<input checked="" type="checkbox"/>	<input type="checkbox"/>	<input checked="" type="checkbox"/>	<input type="checkbox"/>	<input checked="" type="checkbox"/>	<input type="checkbox"/>	<input checked="" type="checkbox"/>	<input type="checkbox"/>	<input checked="" type="checkbox"/>	<input type="checkbox"/>	<input checked="" type="checkbox"/>	<input type="checkbox"/>	<input checked="" type="checkbox"/>
Zone 2	<input type="checkbox"/>	<input type="checkbox"/>	<input checked="" type="checkbox"/>	<input checked="" type="checkbox"/>	<input type="checkbox"/>	<input type="checkbox"/>	<input checked="" type="checkbox"/>	<input checked="" type="checkbox"/>	<input type="checkbox"/>	<input type="checkbox"/>	<input checked="" type="checkbox"/>	<input checked="" type="checkbox"/>	<input type="checkbox"/>	<input type="checkbox"/>	<input checked="" type="checkbox"/>	<input checked="" type="checkbox"/>
Zone 3	<input type="checkbox"/>	<input type="checkbox"/>	<input type="checkbox"/>	<input type="checkbox"/>	<input checked="" type="checkbox"/>	<input checked="" type="checkbox"/>	<input checked="" type="checkbox"/>	<input checked="" type="checkbox"/>	<input type="checkbox"/>	<input type="checkbox"/>	<input checked="" type="checkbox"/>	<input checked="" type="checkbox"/>	<input checked="" type="checkbox"/>	<input checked="" type="checkbox"/>	<input type="checkbox"/>	<input checked="" type="checkbox"/>
Zone 4	<input type="checkbox"/>	<input type="checkbox"/>	<input type="checkbox"/>	<input type="checkbox"/>	<input type="checkbox"/>	<input type="checkbox"/>	<input type="checkbox"/>	<input type="checkbox"/>	<input checked="" type="checkbox"/>	<input checked="" type="checkbox"/>	<input checked="" type="checkbox"/>	<input checked="" type="checkbox"/>	<input checked="" type="checkbox"/>	<input checked="" type="checkbox"/>	<input checked="" type="checkbox"/>	<input checked="" type="checkbox"/>

Zone Light ON
 Zone Light OFF

HEX Data Programming

Some programming sections require that data be entered in a HEX (hexadecimal, or base 16) format. HEX numbering uses the digits 0 through 9 and the letters A through F.

The letters A through F are represented by the number keys 1 through 6. To enter data in HEX format, first press the [*] Key. The "Ready" light will FLASH. Enter the HEX value, then press the [*] Key again to return to the normal data entry mode; the "Ready" light will stop flashing.

To enter HEX numbers:

- A Enter [*][1][*]
- B Enter [*][2][*]
- C Enter [*][3][*]
- D Enter [*][4][*]
- E Enter [*][5][*]
- F Enter [*][6][*]

Enter [*] **before** and **after** each digit. The last digit in each section does not require the final asterisk (*) to be entered.

PROGRAMMING SECTIONS

[01] 1st Phone Number

This is the first telephone number the Communicator will dial; refer to Section [25] Communicator Call Direction.

Enter the telephone number the same way it would be dialled it on a touch-tone phone. Press [#] after the last digit to complete the telephone number programming.

A second dial tone search, as required in a PBX system, can be added by entering HEX 'D' between digits in the phone number. To enter HEX 'D', press [*] [4] [*].

A pause of 4 seconds can be inserted between digits in a telephone number. Enter [*] [3] [*] (HEX 'C') for a 4-second pause between digits.

To dial "*", enter [*] [2] [*] (HEX 'B').

The total number of digits, including dial tone searches and pauses, must not exceed 16.

[02] 1st Account Code

The 1st Account Code is always transmitted to the 1st telephone number to identify the customer. Enter a 4-digit number in Section [02]; HEX digits may be used in the Account Code.

Where a zero is required in the account code, enter HEX 'A' [*] [1] [*].

If a 3-digit code is required, as in 3/1 formats, enter [0] as the LAST digit. The [0] represents a null digit where no pulses are transmitted.

[03] 2nd Phone Number

This is the second telephone number to which the communicator will dial. Refer to Section [01] for programming instructions.

[04] 2nd Account Code

The second account code is always transmitted to the 2nd telephone number. Refer to Section [02] for programming instructions.

Reporting Code Sections [05] to [10]

Sections [05] to [10] contain the communicator reporting codes. A reporting code is transmitted along with the account code with each transmission. If the reporting codes are not programmed, no transmission will be sent when an event occurs. To prevent a transmission from being sent for any event in the following sections, leave it unprogrammed or enter [00] as the reporting code.

Section [05] and [06] each have 6 reporting codes; Sections [07], [08] and [10] each have 7 reporting codes, while Section [09] has 8 reporting codes. When a section is entered, the system expects a series of 2-digit numbers to be entered. The keypad will beep twice and the "Armed" light will FLASH after each 2-digit entry. When the last 2-digit number for a section is entered, the keypad will beep several times, the "Ready" light will be shut OFF and the "Armed" light will come ON. Another section may now be entered for programming.

[05] Zone Alarm Reporting Codes

When Section [05] is entered, the panel expects six 2-digit numbers for the Alarm Reporting Codes for zones 1 to 6. These codes are transmitted when there is an alarm on zones 1 through 6.

Described below are examples of reporting codes and the resulting transmissions using different communication formats. Using different formats requires entering data in the Account Code Section [02] or [04], the Reporting Code Sections [05] to [10], and the Communicator Format Section [23].

3/1 Format - Non-extended reporting

Requires:

- 3-digit account code in sections [02] or [04]. For example, enter 1230 for account code 123
- Format Code [0], [1], [2], [3], [4] depending on receiver type in section [23].
- Single line digit Alarm Reporting Code Section [05]. For example, enter [30] for single digit code 3 (0 = no pulses)

TRANSMISSION SENT: 123 3

4/2 Format - Non-extended reporting

Requires:

- 4-digit account code in sections [02] or [04]. For example, enter 1230 for account code 123
- Format Code [0], [1], [2], [3], [4] depending on receiver type in section [23].
- 2-digit Alarm Reporting Code in section [05]. For example, enter [31] for 2-digit code 31

TRANSMISSION SENT: 1234 31

3/1 Format - Extended reporting

Requires:

- 3-digit Account Code in section [02] or [04]. For example, enter 1230 for code 123
- Format Code [8], [9], [A], [B], [C] depending on receiver type in section [23]
- 2-digit Alarm Reporting Code in section [05]. For example, enter [31] for 2-digit code 31

TRANSMISSION SENT: 1st ROUND 123 3

2nd ROUND 333 1

If a transmission is not needed for a particular reporting code, enter [00] or [FF] to disable that reporting code.

[06] Zone Restoral Reporting Codes

Zone Restoral Codes are transmitted when zones 1 through 6 are restored from an alarm condition. Refer to Section [05] for programming instructions.

[07] Closing (Arming) Reporting Codes / Partial Closing Reporting Code

Closing Reporting Codes are transmitted to identify arming of the system by Access Codes 1 through 6. If Partial Closing is identified in Section [14], the alarm codes for manually bypassed zones will be transmitted when the system is armed with one or more zones bypassed. Refer to Section [05] for programming instructions. The Closing Reporting Codes may be programmed as follows:

[C1] [C2] [C3] [C4] [C5] [C6]

The first digit, HEX 'C', represents "closing", and the second digit represents the Access Code which was used to arm the system. Note that any number or HEX digit may be used for the first digit; check with the intended monitoring station to determine their reporting code preferences.

The Closing Code transmission takes place after the Exit Delay. If the system is armed and then disarmed before the Exit Delay expires, no closing transmission will take place.

The partial closing code, if used, is transmitted with the regular closing code to identify a partial closing.

When the system has been armed using the [*][0] Quick-Arm command or the Auto-Arm feature, Access Code 1 will be transmitted.

[08] Opening (Disarming) Reporting Codes / After Alarm Reporting Code

Opening Reporting Codes are transmitted to indicate disarming of the system by Access Codes 1 through 6. When the system is disarmed by one of the Access Codes, the corresponding reporting code in this section is transmitted.

Refer to Section [07] for examples of reporting code programming.

If the After Alarm Code is programmed, that code will be transmitted when the system is disarmed if an alarm occurred during the previous armed period. This feature allows the monitoring station to know when the user is on the premises and available to receive a report about alarms that occurred while the system was armed.

[09] Priority Alarms and Restorals

Priority Alarms and Restoral codes are transmitted to indicate various trouble and alarm conditions and their restorals. Refer to Section [05] for programming instructions. The following events are reported by the codes in Section [09]:

- [*]+[#] alarm
- [1]+[3] alarm
- [4]+[6] alarm
- [*]+[#] restore
- [1]+[3] restore
- [4]+[6] restore

Note that keypad alarms will only be transmitted if a reporting code is programmed in Section [09].

[10] Maintenance Alarms and Restorals

Maintenance Alarms and Restoral codes are transmitted to indicate various trouble conditions and their restorals. Refer to Section [05] for programming instructions. The following events are reported by the codes in Section [10]:

- Low battery alarm
- AC failure alarm
- Fuse failure alarm
- Automatic Test Code
- Low battery restore
- AC failure restore
- Fuse failure restore

The Automatic Test Code will not be transmitted if periodic downloading is selected in Section [14] Light 3. For Automatic Test Code Reporting, the time between reports (in days) must be programmed in Section [17], and the time of day for the report must be programmed in Section [19].

[11] Zone Definitions

Enter six 2-digit numbers in this section to determine the operating characteristics of each zone.

Zone Definitions Digit 1

The first digit of each Zone Definition determines each zone's audible alarm characteristics and response speed. When programmed as "audible", the siren will sound on alarm; when programmed as "silent", the siren will not sound on alarm.

Zone response times are factory set at 500 ms. When programmed as "fast", the zone response time will be 10ms. When programmed as "slow", the zone response time will be 500 ms or the value programmed at Section [17] Light 5. Refer to Section [17] for information on programming the slow zone response time.

Zone Definitions Digit 1

- [0] Slow / Audible
- [1] Slow / Silent
- [2] Fast / Audible
- [3] Fast / Silent

Zone Definitions Digit 2

Digit 2 determines the zone type as described below:

[0] Standard Delay: Entry and Exit Delays are normally used for Entry/Exit doors. The Exit Delay starts when the system is armed; the zone may be opened and closed during the delay without causing an alarm. When the Exit Delay expires, opening the zone will start the Entry Delay. During the Entry Delay, the keypad buzzer will sound steadily to indicate that the system should be disarmed. If the system is disarmed before the Entry Delay expires, no alarm will be generated.

Entry and Exit Delay times may be independently programmed for 1 to 99 seconds in Section [17]. The default settings are 30 seconds for the Exit Delay, and 45 seconds for the Entry Delay.

[1] Instant: Instant zones are normally used for door and window contacts. Instant zones have the standard Exit Delay, but are “instant” when opened after the Exit Delay expires.

[2] Interior: Interior zones are normally used with interior motion detectors and have the standard Exit Delay. The zone will also have the standard Entry Delay provided that a Delay zone has been activated before the Interior zone. If an Interior zone is activated before a Delay zone, an alarm will be generated.

[3] Interior Home-Away: Home-Away zones operate similarly to Interior zones, but with the following additional feature: if the system is armed and a Delay zone is not activated during the Exit Delay time, the Interior Home-Away zones will be automatically bypassed. This feature allows the system to be armed with the interior zones automatically bypassed so that the user may remain on the premises.

Interior Home-Away zones can have the Entry Delay when Section [32] Light 3 is ON. When Light 3 is ON, the Entry Delay will be applied to all Interior Home-Away zones when the system is armed and the Interior zones are not bypassed. If the Interior Home-Away zones are automatically bypassed or are bypassed by arming with the [*][9] command, the user may enter [*][1] to make the Entry Delay apply to the Interior Home-Away zones.

[4] 24-Hour Siren: 24-Hour Siren zones are active at all times and will sound an alarm even if the panel is disarmed. 24-Hour Siren zones will always activate the siren output.

[5] 24 Hour Siren/Buzzer: These zones operate as 24-Hour Siren zones, except the siren output is activated only when the panel is armed; only the keypad buzzer is activated while the panel is disarmed.

[6] 24 Hour Buzzer: These zones operate as 24-Hour Siren zones except that only the keypad buzzer will be activated when the zone is activated.

[7] Auxiliary Delay: Auxiliary Delay zones operate in the same manner as Standard Delay zones but with different Entry and Exit Delays. The Auxiliary Delay times are programmed in Section [18].

The Auxiliary Delay zones are useful for entrances that may require a longer Entry or Exit Delay time; for example, a zone protecting an overhead garage door may require a longer Entry Delay.

If Section [32] Light 5 is ON, the system may be armed even if the Auxiliary Delay zone is open. Also, the system can be armed with the Auxiliary Delay zone closed and the zone can be opened before that Auxiliary Exit Delay expires. In both cases, the Auxiliary Delay Zone will not be armed until both the Auxiliary Exit Delay expires and the zone is closed.

Zone Definitions Digit 2

- | | |
|-------------------------------|---------------------------------|
| [0] Standard Delay | [5] 24-Hour Siren/Buzzer |
| [1] Instant | [6] 24-Hour Buzzer |
| [2] Interior | [7] Auxiliary Delay |
| [3] Interior/Home-Away | |
| [4] 24-Hour Siren | |

[12] 1st System Option Code

When Section [12] is entered, the 4 Zone Lights, "Ready" and "Armed" lights will indicate which options are enabled. If a light is ON, that option is enabled; if a light is OFF, that option is disabled.

To enable or disable an option, press a number from [1] to [6]; [5] is used for the "Ready" light, and [6] is used for the "Armed" light. If the light indicating the option was OFF, it will come ON; if the light indicating the option was ON, it will go OFF. Press [0] to shut all lights OFF.

LIGHT

- [1] ON = Communicator disabled
 - OFF = Communicator Enabled
- [2] ON = Transmission per 24 hour period
 - OFF = Transmission per armed period
- [3] ON = Alarm display while armed
 - OFF = No alarm display while armed
- [4] ON = DTMF dialling■
 - OFF = Pulse dialling
- [R] ON = N.C. zones (except fire zones)
 - OFF = End-of-line resistor zones▼
- [A] ON = [*]+[#] audible
 - OFF = [*]+[#] silent

[R] = "Ready" light; [A] = "Armed" light

- Factory default settings
- DTMF dialling will default to pulse dialling after 2 unsuccessful DTMF dialling attempts.
- ▼ Must be programmed for UL installations.

[13] 2nd System Option Code

Refer to Section [12] for programming information.

LIGHT

- [1] ON = Zone 4 N.O. without EOL
 - OFF = Zone 4 is normal
- [2] ON = Master Code not user changeable
 - OFF = Master Code user changeable
- [3] ON = Siren squawk enabled■
 - OFF = Siren squawk disabled
- [4] ON = *Not Used*
 - OFF = *Not Used*
- [R] ON = 6th code is one-time use
 - OFF = 6th code is normal Access Code
- [A] ON = 1400 Hz handshake for Radionics formats # 3, 4, B and C
 - OFF = 2300 Hz handshake for Radionics formats # 3, 4, B and C

[R] = "Ready" light; [A] = "Armed" light

- Factory default settings
- With siren squawk enabled, the siren will sound one short burst on arming and two short bursts on disarming.

NOTE: When Auto-Arming is enabled, the siren will sound 1 short burst every 10 seconds for one minute before the panel Auto-Arms unless "Siren During Auto-Arm" is disabled in Section [32] Light 2.

[14] 3rd System Option Code

Refer to Section [12] for programming information.

LIGHT

- [1] ON = Access code required for bypass
 - OFF = Access code not required for bypass
- [2] ON = Enable [*][4] downloading call feature
 - OFF = Disable [*][4] call feature¹
- [3] ON = Periodic downloading²
 - OFF = Periodic test transmission
- [4] ON = [*][4] requires a Access Code
 - OFF = [*][4] does not require Access Code
- [R] • ON = [*][#] Panic Alarm has keypad-audible feedback
 - OFF = [*][#] Panic Alarm does not have keypad-audible feedback
- [A] ON = Partial closings identified³
 - OFF = Partial closings not identified

[R] = "Ready" light; [A] = "Armed" light

- Factory default settings

¹ [*][4] allows downloading to be initiated from the control panel

² The panel can be programmed to periodically call the downloading computer. The cycle time in days for the call is set in Section [19]. The automatic call to the downloading computer can be used to update the panel program and/or to upload status information from the panel.

³ If partial closings to be identified, alarm codes for bypassed zones will be transmitted.

[15] Communication Variables

Enter a 2-digit number in this Section. This number defines the number of attempts the communicator will make to transmit alarm and restoral reports for a zone before the communicator shuts down for that zone. The number of attempts is for the period defined in Section [12], 1st System Option Code, Light 2. The number of communication attempts may be programmed from [00] to [99], where '00' means the communicator will never shut down. Note that the fire zone cannot be shut down; it always transmits.

[16] Zone Bypass Mask

Refer to Section [12] for programming information. If a zone light is ON, that zone can be bypassed; if a zone light is OFF, that zone cannot be bypassed using the [*][1] command. Note that the fire zone cannot be bypassed.

[17] System Times

Six system times are programmed in Section [17]; each time requires a 2-digit number. Do not press the [#] Key during data entry.

[1] Entry Delay (01 to 99 seconds) Location [1] holds the standard Entry Delay time. The default setting is 30 seconds; refer to Section [11] for information on Zone Definitions.

[2] Exit Delay (01 to 99 seconds) Location [2] holds the standard Exit Delay time. The default setting is 45 seconds; refer to Section [11] for information on Zone Definitions.

[3] Siren Cut-Off (01 to 99 minutes) Location [3] determines how long the siren will sound when an alarm is generated. The default setting is 4 minutes.

[4] AC Failure Transmission Delay (01 to 99 minutes) Location [4] determines the length of time before the communicator will transmit an AC failure report. The default setting is 30 minutes.

[5] "Slow" Zone Response Time (01 to 99 x 10 ms) Location [5] determines the "slow" zone response time; this time is programmable from 10 ms to 990 ms. The default Slow Zone Response Time is 500 ms.

NOTE: The fast zone response time is fixed at 10 ms.

[6] Test Transmission Cycle Time (01 to 99 days) Location [6] determines the frequency, in days, of the test transmission made through the communicator or by calling the downloading computer. The default setting is 30 days; refer to Section [14] 3rd System Option Code, Light 3 for information on enabling the test transmission.

[18] Auxiliary Delay Zone Entry/Exit Times

Zones programmed as Type [7] in Section [11] will use the Auxiliary Entry and Exit Delays.

Enter two 3-digit numbers in Section [18] to determine the Auxiliary Entry Delay and the Auxiliary Exit Delay. The default setting for the Auxiliary Entry Delay is 45 seconds; the default setting for the Auxiliary Exit Delay is 60 seconds. Each time may be programmed within the range of [000] to [255] seconds.

[19] System Clock Times

Times for Automatic Arming Time of Day and Test Transmission Time of Day are entered in Section [19] as 4-digit numbers. Do not press the [#] Key during data entry.

The default setting for both times is [9999]; programming these times as [9999] disables the features. A valid time of day in the 24-hour clock format must be programmed for these features to function.

Test Transmission or Periodic Downloading is enabled in Section [14], 3rd System Option Code, Light 3. The cycle time in days for the test transmission or periodic downloading is set in Section [17], System Times. For a test transmission using the communicator, an automatic test code should be entered in Section [10]. For either feature, a valid transmission time must be entered in Section [19].

NOTE: If the Auto-Arm time or the Test Transmission time has a valid time entered when power is applied to the control panel, then a loss-of-time trouble will be generated. Be sure to clear the trouble condition and reset the system clock.

[20] Installer's Code

It is recommended that the Installer's Code be changed when the control panel is installed. Program a new 4-digit code in this section. Only use digits [0] through [9] as code numbers; do not press the [*] or [#] Keys during code entry. If an error is made in entering the code, complete entry of the 4 digits and then enter the section again to correct the code.

[21] Master Code

It is recommended that a new Master Code be programmed when the control panel is installed. Consult with the system's users to determine the new Master Code and program the new 4-digit code in this section. Refer to Section [20] for programming information.

[22] 2nd Master Code

Refer to Section [20] for programming information.

[23] Communication Formats

This section determines the communication format to be used when transmitting information to the two telephone numbers programmed in Sections [01] and [03]. For each telephone number, enter one digit from the list below. Refer to "HEX Data Programming" for instructions on entering HEX numbers.

The format for each phone number is determined by the type of receiver being called. Enter the format number for the 1st telephone number first. Program a format for both telephone numbers even if the first phone number is the only one being used.

Name	Handshake	Formats
[0] Silent Knight / Ademco Slow 10 bps	1400 Hz	3/1,3/2, 4/1 and 4/2 non-extended formats
[1] SESCOA, Franklin, DCI, Vertex 20 bps	2300 Hz	3/1,3/2, 4/1 and 4/2 non-extended formats
[2] Silent Knight Fast 20 bps	1400 Hz	3/1,3/2, 4/1 and 4/2 non-extended formats
[3] Radionics	2300/1400 Hz•	3/1, 4/2 non-extended formats
[4] Radionics	2300/1400 Hz	3/1, 4/2 non-extended with parity format
[5] <i>Do Not Use</i>		
[6] <i>Do Not Use</i>		
[7] <i>Do Not Use</i>		
[8] Silent Knight / Ademco Slow 10 bps	1400 Hz	3/1 extended format
[9] SESCOA, Franklin, DCI, Vertex 20 bps	2300 Hz	3/1 extended format
[A] Silent Knight Fast 20 bps	1400 Hz	3/1 extended format
[B] Radionics	2300 / 1400 Hz•	3/1 extended format
[C] Radionics	2300 / 1400 Hz•	3/1 extended with parity format
[D] <i>Do Not Use</i>		
[E] <i>Do Not Use</i>		
[F] <i>Do Not Use</i>		

- See Section [13] for Radionics handshake option.

Communications Compatibility

All communication formats described here are compatible with the Silent Knight SK9000 and Ademco Model 685 receivers. For UL installations, ensure that the control unit is reporting to one of these receivers.

10 BPS and 20 BPS Formats

10 BPS is the standard slow format used on Silent Knight / Ademco receivers. DATA = 1900 Hz; KISSOFF = 1400 Hz; SPEED = 10 baud

20 BPS is the standard fast format used on the DCI / Franklin / SESCOA and Vertex receivers. DATA = 1800 Hz; KISSOFF = 2300 Hz; SPEED = 20 baud

Radionics Format

For conventional Radionics 3/1 format, the communications mode should be set on either Radionics rounds [B] or Radionics parity [C]. The extended version of the Radionics format is normally used. Use the following guidelines to configure the PC1150 for Radionics format:

- 1 The customer account code must be only 3 digits with a zero making up the 4th digit. For example, enter 1230 to program the account code as 123.
- 2 The zone alarm reporting codes must all be single digit numeric codes with no extended second round being sent; for example, Zone 1 = 10, Zone 2 = 20, and so on. Zero as the second digit prevents the control panel from sending an extended round.
- 3 All non-alarm reporting codes must be set up to send an extended second round. The first digit of the reporting code is used to identify the event, while the second or extended digit is used to associate the event with a particular item. For example,*a reporting code of E3 means "restore zone 3"; E = restore, 3 = zone 3.
- 4 The following is a list of first digit identifiers that should be used with the Radionics format:
 - Restorals "E". For example, E3 = "restore zone 3"
 - Openings "B". For example, B2 = opening by user 2
 - Closings "C". For example, C4 = closing by user 4
 - Troubles "F". For example, F5 = trouble from source 5
 - Miscellaneous "D". For example, D1 = partial closing

[24] Programmable Output Options / PGM Terminal

The PGM output can be programmed to operate in response to various panel operations. The output pulse connects the PGM terminal to the negative power rail.

[01] Not Used

[02] Utility Output, no Access Code

When activated by entering the [*][7] command, the PGM output will go low for 5 seconds and the keypad buzzer will sound.

[03] Utility Output, any Access Code

The same as [02], except the command is [*][7] [any valid Access Code].

[04] 5-Second Reset Pulse

When this option is selected, the PGM output is normally low. That is, it is the reverse of all other options which are normally high and go low when activated. To activate this output, enter the [*][7] command. The PGM terminal will go high (open circuit), and thus remove power from the devices connected. The keypad buzzer will sound for the 5-second period.

[05] Courtesy Pulse

This option provides an output which follows the Entry and Exit Delays. It can be used to turn on a courtesy light near the exit door for the duration of the Entry or Exit Delays.

[06] Keypad Buzzer Follow Mode

The PGM output will go low as long as the keypad buzzer is ON for 24 Hour Buzzer Zone, Door Chime, Entry Delay and Auto-Arm Alert.

[07] System Status (Armed / Disarmed)

The PGM output switches to and remains at ground as long as the panel is armed. The output goes high (open) when the panel is disarmed.

[08] Strobe Output (Latched Alarm Output)

The PGM switches to ground on an alarm and remains low until the panel is disarmed. It can be used to indicate that an alarm has occurred before entering the premises.

[09] Failure to Communicate

The PGM output switches to ground if the system fails to communicate after 8 attempts to each phone number that will be tried according to Section [25] Communicator Call Direction Options. The output remains low until a successful communication takes place or until the Unsuccessful Communication Attempt trouble is cleared. This option can be used to link two systems together so that if one fails to communicate, the other system will report the failure.

[25] Communicator Call Directions

Section [25] determines how the communicator will call the telephone numbers programmed in Sections [01] and [03] to report the following events:

- Zone Alarms and Restorals
- Access Codes Openings and Closings
- Priority Alarms and Restorals
- Maintenance Alarms and Restorals

Enter one digit from the list below for each of the reporting groups. The default setting is [1] for all groups.

[0] No transmission

[1] Call 1st phone number and back-up to the 2nd phone number when Section [13] Light 1 is OFF and the panel has made 8 unsuccessful attempts on the 1st phone number.

[2] Call the 2nd phone number only

[3] Always call both phone numbers

NOTE: If the [#] Key is pressed during data entry, the keypad will return to the Installer's Programming Mode and any data entered in this section will not be saved.

[26] Downloading Telephone Number

Enter the Downloading Telephone Number in this section. This telephone number is dialed during automatic downloading or when downloading is requested with the [*][4] command. Refer to Section [14], 3rd System Option Code, Lights 2 and 3. Refer to Section [01] 1st Phone Number for instructions on programming telephone numbers.

[27] Downloading Access Code

This 4-digit code allows the panel to confirm that it is communicating with the intended downloading computer. Enter 4 digits using the numbers 0 through 9 only. The default code is [1515].

[28] Panel Identification Code

This 4-digit code allows the downloading computer to confirm the identity of the control panel. Enter 4 digits using the number keys 0 through 9 only. The default code is [1501].

[29] Number of Rings Before Answering

Section [29] sets the number of rings before the panel will pick-up the line and answer the call. Refer to Section [31] for information on using the system with an answering machine connected to the same phone line.

[30] Reset to Factory Default

Software Reset

Entering Section [30] will reset the control panel's programming to the default settings. When Section [30] is entered, the keypad will beep several times and the "Trouble" light will come ON during the reset sequence.

Hardware Reset

If the Installer's Code is forgotten and a software reset cannot be performed, the panel may be reset to the default settings with the following method:

- 1 Remove all power, AC and battery, from the panel
- 2 Short the pins marked EEPROM RESET
- 3 While maintaining the short, power-up the panel and wait for at least 10 seconds before removing the short
- 4 After at least 10 seconds, remove the short. The keypad buzzer will beep and the panel's programming will be reset to the default settings

[31] 4th System Option Code

Refer to Section [12] for programming instructions.

LIGHT

- [1] ON = Able to answer call from downloading computer
 - OFF = Cannot answer call from downloading computer
- [2] ON = Enable callback to downloading computer
 - OFF = Disable callback to downloading computer
- [3] ON = Enable answering machine over-ride
 - OFF = Disable answering machine over-ride
- [4] ON = "System" light flashes when armed to indicate alarm memory
 - OFF = "System" light normal
- [R] ON = Quick-Arm enabled
 - OFF = Quick-Arm disabled
- [A] ON = Restore on siren time-out (if zone is restored)
 - OFF = Restore as follower (when zone restores)

[R] = "Ready" light; [A] = "Armed" light

- Factory default

Downloading and Answering Machines

The answering machine override feature allows an answering machine to be connected to the same telephone line as the control panel. Turn Light [3] in Section [31] ON to enable this feature.

To access the panel, have the downloading computer call the control panel and let the line ring for 1 or 2 rings only. Hang up the line and then call the panel back within the time programmed in Section [33]; the panel will then answer the second call on the first ring.

If Light [3] is OFF, it is assumed that there is no answering machine connected to the telephone line, and the panel will capture the line after the set number of rings.

Note that if Light [3] is OFF and an answering machine is connected to the line and is set to answer before the panel, the panel will be unable to receive a call from the downloading computer. If the panel is set to answer before the answering machine, the answering machine will be unable to receive incoming calls.

[32] 5th System Option Code

Refer to Section [12] for programming instructions.

LIGHT

- [1] ON = Loss of AC will not cause an AC trouble
 - OFF = Loss of AC will cause AC trouble■
- [2] ON = No siren during Auto-Arm
 - OFF = 1 burst of siren every 10 seconds during Auto-arm pre-alert
- [3] ON = Home-Away zones will have an entry delay when tripped
 - OFF = Home-Away zones act as interior when tripped
- [4] ON = Quick-Exit is enabled ([*][0] ignores one activation of a delay zone)
 - OFF = Quick-Exit is disabled
- [R] ON = Auxiliary Delay zones can be force armed
 - OFF = Auxiliary Delay zones cannot be force armed
- [A] ON = All zones except fire will be bypassed for 60 seconds upon power-up
 - OFF = All zones are active upon power-up

[R] = "Ready" light; [A] = "Armed" light

- Factory default
- This feature must be enabled for UL installations.

[33] Answering Machine Double Call Timer

Refer to Section [31] Light 3. Section [33] determines the acceptable length of time between the first and second calls when using the answering machine override feature.

[90] Installer's Lockout Enable

With this feature enabled, the Installer's Code and Downloading Access Code will not be restored to the default setting when the panel's programming is restored to its default settings through a software or hardware reset. This feature is designed to prevent tampering with the installer's programming sections.

A control panel with this feature enabled will click its phone line relay 10 times upon power-up to indicate that the Installer's Lockout is enabled.

Ensure that the new Installer's Code has been entered correctly before enabling this feature. There is no way to re-entering the installer's programming mode without the new Installer's Code.

[91] Installer's Lockout Disable

Entering Section [91] when in the installer's programming mode will disable the Installer's Lockout feature.

NOTE: Panels returned to DSC with the Installer's Lockout feature enabled and no other apparent problems will be subject to an additional service charge.

PROGRAMMING WORKSHEETS

NOTE: In sections [01] to [10], do not enter data into sections that are not used.

[01] 1st Phone Number Page 14

Enter [0] for the digit 0 in the phone number. Enter [*4*] (HEX D) for additional dial tone detection between number digits, as in local PBX systems. Enter [#] to end the phone number entry

[02] 1st Customer Account Code Page 14

Enter [*1*] (HEX A) for the digit "0" in the account code. For a 3-digit code, enter [0] for the 4th digit.

[03] 2nd Phone Number Page 14

[04] 2nd Customer Account Code Page 14

[05] Zone Alarm Reporting Codes Page 14

For single digit reporting codes, enter [0] as the second digit.

Default

3, 1, ___ Zone 1 Alarm Enter [*1*] (HEX A) to transmit a "0" (zero = 10 pulses)

3, 2, ___ Zone 2 Alarm

3, 3, ___ Zone 3 Alarm

3, 4, ___ Zone 4 Alarm

[06] Zone Restoral Reporting Codes Page 15

For single digit reporting codes, enter [0] as the second digit.

Default

9, 1, ___ Zone 1 Restoral Enter [*1*] (HEX A) to transmit a "0" (zero = 10 pulses)

9, 2, ___ Zone 2 Restoral

9, 3, ___ Zone 3 Restoral

9, 4, ___ Zone 4 Restoral

[07] Closing (Arming) Reporting Codes / Partial Closing Reporting Code Page 15

- Access Code 1
- Access Code 2
- Access Code 3
- Access Code 4
- Access Code 5
- Access Code 6
- Partial Closing Code

[08] Opening (Disarming) Reporting Codes / After Alarm Reporting Code Page 16

The "after alarm" code is sent on disarming if an alarm occurred during the previous armed period.

- Access Code 1
- Access Code 2
- Access Code 3
- Access Code 4
- Access Code 5
- Access Code 6
- After Alarm Code

[09] Priority Alarms & Restorals Page 16

Actuation of the keypad zones will immediately transmit both an alarm and restoral code. There is no delay on the restoral code transmission.

Default

- F, 1 **Not Used**
- 2, 2 [*]+[#] Alarm
- 1, 2 [1]+[3] Alarm
- 4, 2 [4]+[6] Alarm
- E, 1 **Not Used**
- 9, 6 [*]+[#] Restore
- 9, 8 [1]+[3] Restore
- 9, 9 [4]+[6] Restore

[10] Maintenance Alarms & Restorals Page 16

Default

<u>F</u> , <u>3</u>	<u> </u>	Low Battery Alarm
<u>F</u> , <u>4</u>	<u> </u>	AC Fail Alarm
<u>F</u> , <u>8</u>	<u> </u>	Fuse Failure Alarm
<u>E</u> , <u>3</u>	<u> </u>	Low Battery Restore
<u>E</u> , <u>4</u>	<u> </u>	AC Fail Restore
<u>E</u> , <u>8</u>	<u> </u>	Fuse Failure Restore
<u>F</u> , <u>F</u>	<u> </u>	Automatic Test Code

For automatic test code reporting, time between reports (in days) must be specified in Section [17], and time of day for the report must be entered in Section [19].

[11] Zone Definitions Page 16

NOTE: When defining zones, assign delay zones first to zones 1,2,3... then assign the other types to the remaining zones in any order desired.

Default

<u>0</u> , <u>0</u>	<u> </u>	Zone 1
<u>0</u> , <u>1</u>	<u> </u>	Zone 2
<u>0</u> , <u>1</u>	<u> </u>	Zone 3
<u>0</u> , <u>1</u>	<u> </u>	Zone 4

Digit #1

- 0 Slow, Audible
- 1 Slow, Silent
- 2 Fast, Audible
- 3 Fast, Silent

Digit #2

- 0 Standard Delay
- 1 Instant
- 2 Interior
- 3 Interior, Home-Away
- 4 24 Hour Siren
- 5 24 Hour Siren/Buzzer
- 6 24 Hour Buzzer
- 7 Auxilliary Delay

[12] 1st System Option Code Page 18

Default

<u>ON</u>	<u> </u>	Zone Light 1
<u>OFF</u>	<u> </u>	Zone Light 2
<u>OFF</u>	<u> </u>	Zone Light 3
<u>OFF</u>	<u> </u>	Zone Light 4
<u>ON</u>	<u> </u>	"Ready" Light
<u>ON</u>	<u> </u>	"Armed" Light

Zone Light ON

Communicator disabled	Communicator enabled
TX limit to 24 hour period •	TX limit to armed period
Alarm display while armed	No alarm display while armed
DTMF dialling	Pulse dialling
N.C. zones (except fire)	EOL resistor zones•
Keypad [P]anic audible (siren)	Keypad [P]anic silent (siren)

• Must be programmed for UL installations

[13] 2nd System Option Code Page 18

<i>Default</i>			<i>Zone Light ON</i>	<i>Zone Light OFF</i>
<u>OFF</u>	<input type="checkbox"/>	Zone Light 1	Zone 4 N.O. without EOL	Zone 4 normal
<u>OFF</u>	<input type="checkbox"/>	Zone Light 2	Master Code not changeable	Master Code changeable
<u>OFF</u>	<input type="checkbox"/>	Zone Light 3	Siren Squawk enabled•	Siren Squawk disabled
<u>OFF</u>	<input type="checkbox"/>	Zone Light 4	NOT USED	NOT USED
<u>OFF</u>	<input type="checkbox"/>	"Ready" Light	6th code is maid's code	6th code normal
<u>OFF</u>	<input type="checkbox"/>	"Armed" Light	1400 Hz Radionics	2300 Hz Radionics

• With Siren Squawk enabled, the siren will sound one short burst on arming and two short bursts on disarming.

[14] 3rd System Option Code Page 19

<i>Default</i>			<i>Zone Light ON</i>	<i>Zone Light OFF</i>
<u>OFF</u>	<input type="checkbox"/>	Zone Light 1	Access Code req'd for bypass	Code not required
<u>OFF</u>	<input type="checkbox"/>	Zone Light 2	[*] [4] Enabled	[*] [4] Disabled
<u>OFF</u>	<input type="checkbox"/>	Zone Light 3	Periodic downloading	Periodic test transmit
<u>OFF</u>	<input type="checkbox"/>	Zone Light 4	[*] [4] access code required	[*] [4] no code required
<u>ON</u>	<input type="checkbox"/>	"Ready" Light	[P]anic audible (buzzer)	[P]anic silent
<u>OFF</u>	<input type="checkbox"/>	"Armed" Light	Partial closing identified	Not identified

[15] Communication Variables Page 19

Default

0,3 Maximum transmissions per burglary zone

Enter digits from "01" to "99" for number of transmissions per zone during the period as defined in Section [12], 1st System Option Code, Zone Light 2; [00] = unlimited transmissions per burglary zone. Note that the Fire zone always transmits.

[16] Zone Bypass Mask Page 19

If the Zone Light is ON, the zone can be bypassed using the [*][1] command.

Default

<u>ON</u>	<input type="checkbox"/>	Zone Light 1	If a zone is defined as a fire zone, it cannot be bypassed.
<u>ON</u>	<input type="checkbox"/>	Zone Light 2	
<u>ON</u>	<input type="checkbox"/>	Zone Light 3	
<u>ON</u>	<input type="checkbox"/>	Zone Light 4	

[17] System Times Page 19

Default

<u>3</u> , <u>0</u> <u> </u>	Entry Delay (seconds)
<u>4</u> , <u>5</u> <u> </u>	Exit Delay (seconds)
<u>0</u> , <u>4</u> <u> </u>	Siren Cut-off (minutes)
<u>3</u> , <u>0</u> <u> </u>	AC fail transmission delay (minutes)
<u>5</u> , <u>0</u> <u> </u>	Slow zone response time (x 10 ms)
<u>3</u> , <u>0</u> <u> </u>	Test transmission cycle or auto download cycle time (days)

Valid entries are "01" to "99"; do not enter "00".

[18] Auxiliary Delay Zone Times Page 20

Default

<u>0</u> , <u>4</u> , <u>5</u> <u> </u>	Entry Time (seconds)
<u>0</u> , <u>6</u> , <u>0</u> <u> </u>	Exit Time (seconds)

Valid entries are "001" to "255".

[19] System Clock Times Page 20

Default

<u>9</u> , <u>9</u> , <u>9</u> , <u>9</u> <u> </u>	Automatic Arming (time of day)
<u>9</u> , <u>9</u> , <u>9</u> , <u>9</u> <u> </u>	Test Transmission or Auto Download (time of day)

Enter time in 24-hour clock format. If not used, program as [9999] to disable. **NOTE:** For UL installations, the Auto-Arm feature must always be disabled.

[20] Installer's Code Page 20

Default

1,2,1,2

For Sections [20], [21] and [22]:

Enter 4 digits from "0" to "9".

Do not enter [.] or [#].

[21] Master Code Page 20

Default

1,2,3,4

[22] 2nd Master Code Page 20

2nd Master Code can be erased by entering [*1111]; [AAAA] = not programmed

Default

A,A,A,A

[23] Communication Formats Page 21

Default

B 1st Telephone Number

B 2nd Telephone Number

A format for both numbers must be programmed, even if the second telephone number is not used.

Enter one HEX digit from [0] to [F] for each phone number from the following list:

Name	Handshake	Formats
[0] Silent Knight / Ademco Slow 10 bps	1400 Hz	3/1, 3/2, 4/1 and 4/2 non-extended formats
[1] Sescoa, Frankline, DCI, Vertex 20 bps	2300 Hz	3/1, 3/2, 4/1 and 4/2 non-extended formats
[2] Silent Knight Fast 20 bps	1400 Hz	3/1, 3/2, 4/1 and 4/2 non-extended formats
[3] Radionics	2300/1400 Hz•	3/1, 4/2 non extended formats
[4] Radionics	2300/1400 Hz	3/1, 4/2 non-extended with parity format
[5] <i>Do Not Use</i>		
[6] <i>Do Not Use</i>		
[7] <i>Do Not Use</i>		
[8] Silent Knight / Ademco Slow 10 bps	1400 Hz	3/1 extended format
[9] Sescoa, Franklin, DCI, Vertex 20 bps	2300 Hz	3/1 extended format
[A] Silent Knight Fast 20 bps	1400 Hz	3/1 extended format
[B] Radionics	2300 / 1400 Hz•	3/1 extended format
[C] Radionics	2300 / 1400 Hz•	3/1 extended with parity format
[D] <i>Do Not Use</i>		
[E] <i>Do Not Use</i>		
[F] <i>Do Not Use</i>		

- See Section [13] for Radionics handshake option.

[24] Programmable Output Options (PGM Terminal) Page 22

Enter 2 digits from "0" to "9" only.

Default

<u>0,4,0</u> <u> </u> Programmable Output	[01] <i>Not Used</i>
	[02] Utility Output, [*] [7] No Access Code
	[03] Utility Output, [*] [7] Any Access Code
	[04] 5 Second Reset Pulse [*] [7]
	[05] Courtesy Pulse (follows Entry/Exit delays)
	[06] Keypad Buzzer Follow Mode•
	[07] System Status (arm/disarm) Output
	[08] Strobe Output (latched alarm output)
	[09] Failure to Communicate Output

- [06] Buzzer follows the entry delay, door chime, auto-arm alert period and 24 hour buzzer zone.

[25] Communicator Call Direction Options Page 23

This section must be completely programmed; do not press [#] to exit until all entries are completed.

Default

- | | | |
|--------------------|-----------------------------------|-------------------------------------|
| <u>1</u> <u> </u> | Zone Alarms and Restorals | [0] No transmissions for this group |
| <u>1</u> <u> </u> | Access Code Openings and Closings | [1] Call 1st number |
| <u>1</u> <u> </u> | Priority Alarms and Restorals | [2] Call 2nd phone number only |
| <u>1</u> <u> </u> | Maintenance Alarms and Restorals | [3] Always call both phone numbers |

[26] Downloading Telephone Number Page 23

This telephone number is used by the panel to call the downloading computer either by the periodic download function or through the use of the [*] [4] command. Refer to Section [01] for information on programming telephone numbers.

[27] Downloading Access Code Page 23

Default

1,5,1,5

This code allows the panel to confirm that a valid downloading computer is requesting access to the panel.

[28] Panel Identification Code Page 23

Default

1,5,0,1

This code confirms the panel's identity to the downloading computer.

[29] Number of Rings Before Answering Page 23

Enter a number from 01 to 12 to set the number of rings before the panel will answer.

Default

0,8

[30] Reset To Factory Default Page 24

[25] Communicator Call Direction Options Page 23

This section must be completely programmed; do not press [#] to exit until all entries are completed.

Default

- | | | |
|--------------------|-----------------------------------|-------------------------------------|
| <u>1</u> <u> </u> | Zone Alarms and Restorals | [0] No transmissions for this group |
| <u>1</u> <u> </u> | Access Code Openings and Closings | [1] Call 1st number |
| <u>1</u> <u> </u> | Priority Alarms and Restorals | [2] Call 2nd phone number only |
| <u>1</u> <u> </u> | Maintenance Alarms and Restorals | [3] Always call both phone numbers |

[26] Downloading Telephone Number Page 23

This telephone number is used by the panel to call the downloading computer either by the periodic download function or through the use of the [*] [4] command. Refer to Section [01] for information on programming telephone numbers.

[27] Downloading Access Code Page 23

Default

1,5,1,5

This code allows the panel to confirm that a valid downloading computer is requesting access to the panel.

[28] Panel Identification Code Page 23

Default

1,5,0,1

This code confirms the panel's identity to the downloading computer.

[29] Number of Rings Before Answering Page 23

Enter a number from 01 to 12 to set the number of rings before the panel will answer.

Default

0,8

[30] Reset To Factory Default Page 24

[31] 4th System Option Code**Page 24***Default***Zone Light ON****Zone Light OFF**

<u>ON</u>	<input type="checkbox"/>	Zone Light 1	Enable download answer	Disable answer
<u>OFF</u>	<input type="checkbox"/>	Zone Light 2	Enable download callback	Disable callback
<u>ON</u>	<input type="checkbox"/>	Zone Light 3	Answering machine over-ride	Disable over-ride
<u>ON</u>	<input type="checkbox"/>	Zone Light 4	"System" flashes on alarm when armed	"System" light normal•
<u>ON</u>	<input type="checkbox"/>	"Ready" Light	Quick-Arm enabled	Quick-Arm disabled
<u>OFF</u>	<input type="checkbox"/>	"Armed" Light	Restore on siren time out	Restore as follower

- If zone light 4 is ON, bypass status will always be shown. If zone light 4 is OFF, bypass status is shown only when the panel is disarmed.

NOTE: For UL installations, the Quick-Arm feature must be disabled.

[32] 5th System Option Code**Page 25***Default***Zone Light ON****Zone Light OFF**

<u>OFF</u>	<input type="checkbox"/>	Zone Light 1	AC excluded from trouble	AC included•
<u>ON</u>	<input type="checkbox"/>	Zone Light 2	No siren during auto-arm	Siren during auto-arm
<u>OFF</u>	<input type="checkbox"/>	Zone Light 3	Home/away with delay	Home/away as interior
<u>ON</u>	<input type="checkbox"/>	Zone Light 4	Quick exit enabled■	Quick exit disabled
<u>OFF</u>	<input type="checkbox"/>	Zone Light 5	Force arm on auxiliary delay	Auxiliary delay normal
<u>OFF</u>	<input type="checkbox"/>	Zone Light 6	60 s bypass on power-up	Zones active on power up.

- This feature must be enabled for UL installations.

- This feature must not be enabled for UL installations.

[33] Answering Machine Double Call Timer**Page 25***Default*

0,6,0 Valid entries are "001" to "249"

[90] Installer's Lockout Enable Page 25**[91] Installer's Lockout Disable Page 25****WARNING!**

Panels returned to DSC with the Installer's Lockout enabled and no other apparent problems will be subject to an additional service charge!

ALIGN PINS ON BOTTOM OF COMMUNICATOR WITH SOCKETS ON PC1150 CONTROL PANEL AND PRESS TOGETHER. ENSURE ALL PINS ARE FULLY INSERTED INTO SOCKETS. NOTE THAT THE NUMBER OF PINS AND SOCKETS ENSURES THE COMMUNICATOR WILL ATTACH TO THE CONTROL PANEL IN ONLY ONE ORIENTATION (WITH THE COMMUNICATOR'S SCREW TERMINALS FACING UP, AWAY FROM THE CONTROL PANEL'S SCREW TERMINALS).

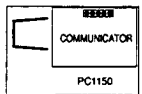

ASSEMBLED UNIT. NOTE ORIENTATION OF TERMINAL STRIPS.

KEYPAD RIBBON WIRE
NOTE ORIENTATION OF WIRE WHEN INSERTING INTO SOCKET

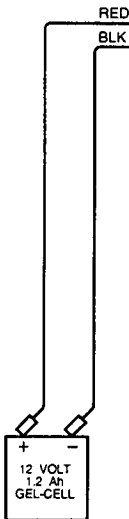
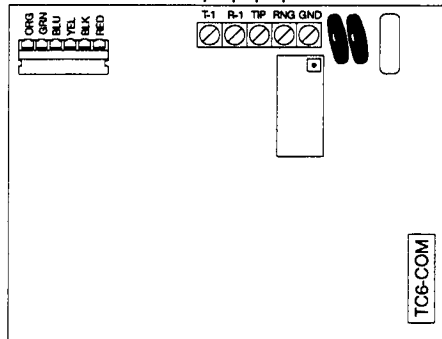
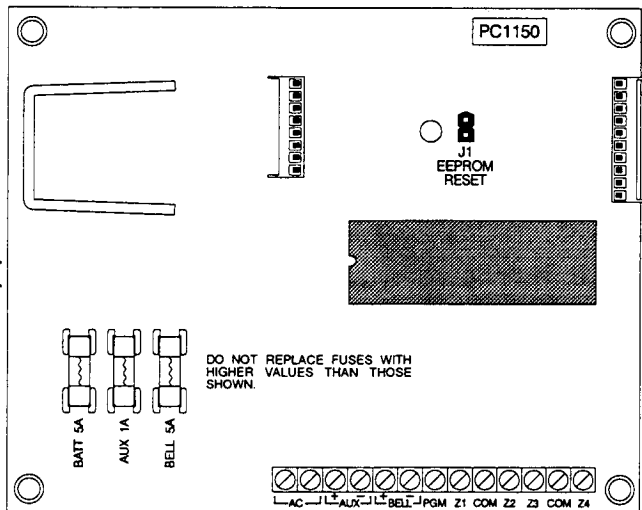
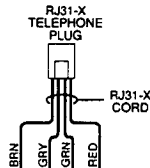
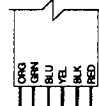

BATTERY CAPACITY FOR EMERGENCY STANDBY IS AT LEAST 4 HOURS IF THE TOTAL LOAD (BELL & AUX OUTPUTS) IS 600 mA OR LESS.

BATTERY CHARGE CURRENT IS 100 mA MAX.

RECOMMENDED BATTERY IS YUKASA NP4-12

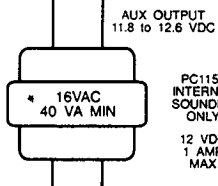

UL LISTED TRANSFORMER
60 Hz

DO NOT CONNECT TRANSFORMER TO A RECEPTACLE CONTROLLED BY A SWITCH. TRANSFORMER MUST BE UL LISTED AND HAVE A RESTRAINING MEANS.

RECOMMENDED TRANSFORMER IS:
BASLER ELECTRIC
BE 116240CAA-0002.

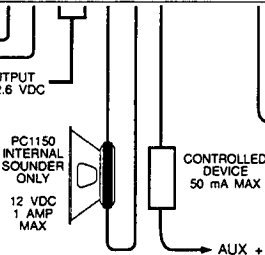

RECOGNIZED LIMITED ENERGY CABLE SHOULD BE USED. OBSERVE NEC WIRING REQUIREMENTS AND LOCAL CODES AS DEFINED BY THE AUTHORITY HAVING JURISDICTION.

REFER TO INSTRUCTION MANUAL 29000XXX R0 FOR COMPLETE OPERATING INSTRUCTIONS.

TEMPERATURE RANGE: 0°C-47°C (32°F-120°F)
MAXIMUM HUMIDITY: 85% R.H.

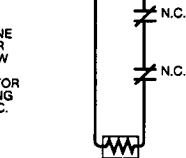
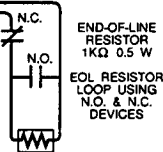

SECURITY DETECTION DEVICES THAT REQUIRE POWER FROM THE CONTROL PANEL MUST OPERATE OVER THE VOLTAGE RANGE OF 10.0 TO 14.0 VDC.

THE DSC "BRAVO" IS A RECOMMENDED U.L. LISTED MOTION DETECTOR.

LIMITED WARRANTY

Digital Security Controls Ltd. warrants that for a period of twelve months from the date of purchase, the product shall be free of defect in materials and workmanship under normal use and that in fulfillment of any breach of such warranty, Digital Security Controls Ltd. shall, at its option, repair or replace the defective equipment upon return of the equipment to its repair depot. This warranty applies only to defects in parts and workmanship and not to damage incurred in shipping or handling, or damage due to causes beyond the control of Digital Security Controls Ltd. such as lightning, excessive voltage, mechanical shock, water damage, or damage arising out of abuse, alteration or improper application of the equipment.

The foregoing warranty shall apply only to the original buyer, and is and shall be in lieu of any and all other warranties, whether expressed or implied and of all other obligations or liabilities on the part of Digital Security Controls Ltd. This warranty contains the entire warranty. Digital Security Controls Ltd. neither assumes, nor authorizes any other person purporting to act on its behalf to modify or to change this warranty, nor to assume for it any other warranty or liability concerning this product.

In no event shall Digital Security Controls Ltd. be liable for any direct, indirect or consequential damages, loss of anticipated profits, loss of time or any other losses incurred by the buyer in connection with the purchase, installation or operation or failure of this product.

WARNING: Digital Security Controls Ltd. recommends that the entire system be completely tested on a regular basis. However, despite frequent testing, and due to, but not limited to, criminal tampering or electrical disruption, it is possible for this product to fail to perform as expected.

FCC COMPLIANCE STATEMENT

This equipment generates and uses radio frequency energy, and if not installed and used properly, in strict accordance with the manufacturer's instructions, may cause interference to radio and television reception. It has been type tested and found to comply with the limits for a class "B" computing device in accordance with the specifications in Subpart "B" of Part 15 of FCC Rules, which are designed to provide reasonable protection against such interference in any residential installation. However, there is no guarantee that interference will not occur in a particular installation. If this equipment does cause interference to radio or television reception, which can be determined by turning the equipment off and on, the user is encouraged to try to correct the interference by one or more of the following measures.

- Reorient the receiving antenna.
- Relocate the equipment with respect to the receiver.
- Move the equipment away from the receiver.
- Plug the equipment into a different outlet so that the equipment and the receiver are on different circuits.

If necessary, the user should consult the dealer or an experienced radio/television technician for additional suggestions. The user may find the following booklet prepared by the FCC useful: "How to Identify and Resolve Radio/Television Interference Problems".

This booklet is available from the U.S. Government Printing Office, Washington D.C. 20402, Stock # 004-000-00345-4

Notification to Telephone Company

Upon request, the customer shall notify the telephone company of the particular line on which the connection will be made, and provide the ringer equivalence of the protective circuit.

FCC Registration Number: F32CAN-73151-AI-E

Ringer Equivalence Number: 0.1B

Malfunction of the Equipment

In the event that the PC1150 should fail to operate properly, the customer shall disconnect the equipment from the telephone line to determine if it is the customer's equipment which is not working properly, or if the problem is with the telephone company network. If the problem is with the PC1150, the customer shall discontinue use until it is repaired.

Telephone Connection Requirements

Except for the telephone company provided ringers, all connections to the telephone network shall be made through standard plugs and telephone company provided jacks, or equivalent, in such a manner as to allow for easy, immediate disconnection of the terminal equipment. Standard jacks shall be so arranged that, if the plug connected there is withdrawn, no interference to the operation of the equipment at the customer's premises which remains connected to the telephone network shall occur by reason of such withdrawal.

NOTE: Ensure that plugs and jacks meet the dimension, tolerance and metallic plating requirements of 47 C.F.R. Part 68, Subpart F.

Incidence of Harm

Should terminal equipment or protective circuitry cause harm to the telephone network, the telephone company shall, where practicable, notify the customer that temporary disconnection of service may be required; however, where prior notice is not practicable, the telephone company may temporarily discontinue service if such action is deemed reasonable in the circumstances. In the case of such temporary discontinuance, the telephone company shall promptly notify the customer and will be given the opportunity to correct the situation. The customer also has the right to bring a complaint to the FCC if he feels the disconnection is not warranted.

Change in Telephone Company Equipment or Facilities

The Telephone Company may make changes in its communications facilities, equipment, operations or procedures, where such actions are reasonably required and proper in its business. Should any such changes render the customer's terminal equipment incompatible with the telephone company facilities the customer shall be given adequate notice to the effect of the modifications to maintain uninterrupted service.

General

This equipment should not be used on coin telephone lines. Connection to party line service is subject to state tariffs.

Ringer Equivalence Number (REN)

The REN is useful to determine the quantity of devices that you may connect to your telephone line and still have all of those devices ring when your telephone number is called. In most but not all areas, the sum of the RENs of all devices connected to one line should not exceed five (5). To be certain of the number of devices that you may connect to your line, you may want to contact your local telephone company.

Equipment Maintenance Facility

Digital Security Controls Ltd.

160 Washburn St.

Lockport, NY 14094